

DALI CONTROL SYSTEM

Nindömā



CATALOG PRODUCT

-DALI CONTROL SYSTEMS-

Daftar Isi

DALI to BACnet Server Gateway

-
- | | |
|--------------------------|-----|
| - NDAL-(064/128)0200-BAC | 001 |
| - NDAL-0640500-BAC | 003 |

DALI to Modbus TCP Server Gateway

-
- | | |
|--------------------|-----|
| - NDAL-0640500-MBS | 005 |
|--------------------|-----|

DALI Relay Controller

-
- | | |
|------------|-----|
| - NDLR05-1 | 007 |
| - NDLR10-1 | 008 |
| - NDLR10-2 | 009 |

DALI Swicth Panel Manual

-
- | | |
|--|-----|
| - N6-EDA1 N6-DAlIapa EDA1 ? | 010 |
| - N-EDA1, N-EDA2 , N-EDA3, N-EDA4 | 011 |

DALI to BACnet Server Gateway

NDAL-(064/128)0200-BAC



Order Codes :

- NDAL-0640200-BAC (64 ballasts, 1 DALI channel)
- NDAL-1280200-BAC (128 ballasts, 2 DALI channels)

HOW IT WORKS

The Nindoma **NDAL-(064/128)0200-BAC** Gateway has been specially designed to work as a translator between a DALI installation and BACnet or BACnet MSTP based control and monitoring system.

Nindoma acts as a master in the DALI bus, allowing both BACnet IP and BACnet MSTP client/master devices to read and write on all configured DALI signals.

BACnet MSTP devices are connected to the serial port of the gateway, while BACnet IP devices are connected to the Ethernet port. On the DALI side, the gateway simulates a DALI-2 master device allowing other DALI/DALI-2 devices to present in the DALI channels.

Configuration project and DALI commissioning is done through Nindoma MAPS.

FEATURES

- Handles conversion between BACnet (IP & MSTP) and DALI/DALI-2 ballasts and DALI-2 sensors (occupancy and light instances)
- Support for BACnet IP or BACnet MSTP, not both simultaneously*
- Designed following DALI IEC 62386 standard and certified by DiiA
- Supports parts 201, 202 y 207 for ECGs
- Supports parts 303 and 304 for Sensors
- DALI line scan (ballast detection) and commissioning
- Configuration through IP or USB (Console) port
- Front cover LED indicators to provide easy to check communication status on both the Ethernet and serial ports
- Includes Nindoma MAPS with automatic updates for both Nindoma MAPS and Gateway's firmware

* NDAL-1280200-BAC does not offer BACnet MSTP communication

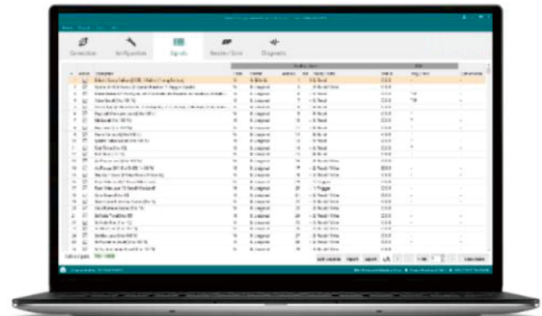

INTEGRATION EXAMPLE

VERSION SUPPORTING 1 DALI CHANNEL

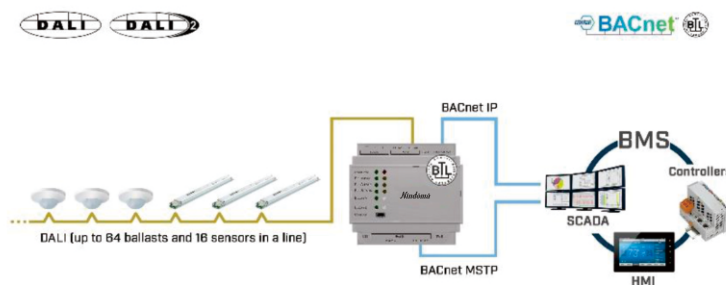

VERSION SUPPORTING 2 DALI CHANNELS

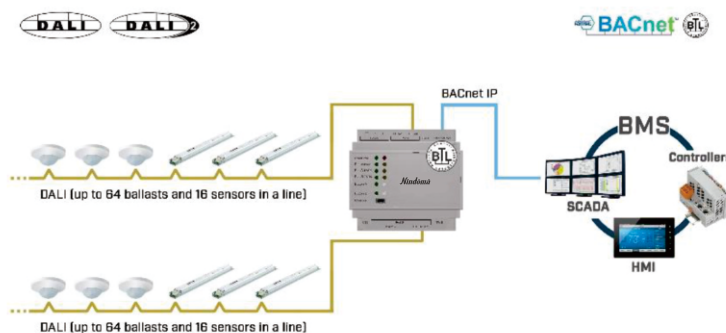

CONNECTIONS

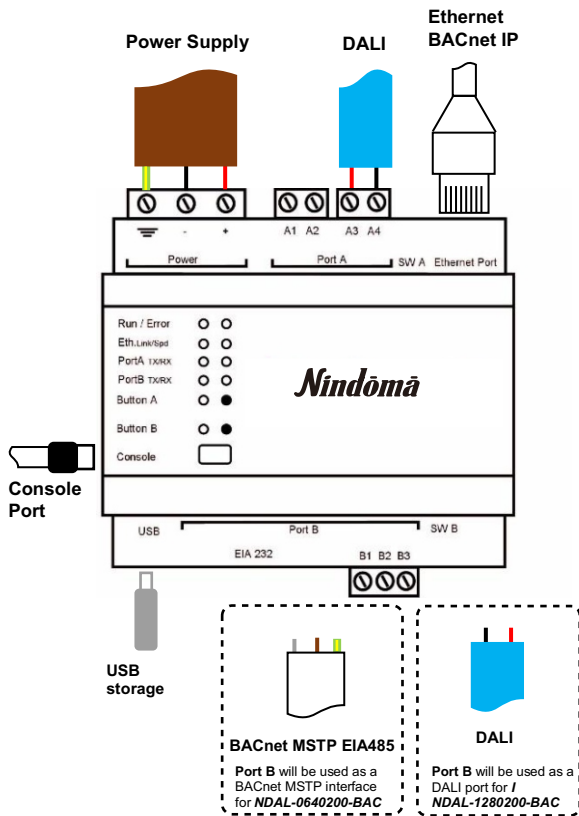

PROTOCOLS



DALI is an industry-standardized protocol, for digital lighting control, and is specified in the multi-part international standard **IEC 62386**

The digital nature of DALI allows **two-way communication** between devices, so that a device can report a failure, or answer a query about its status or other information.

Wiring is relatively simple; DALI power and data is carried by the same pair of wires, without the need for a separate bus cable

For further information, please visit <https://www.digitalilluminationinterface.org>



BACnet is the Data Communication Protocol for Building Automation and Control Networks. Developed under the auspices of the American Society of Heating, Refrigerating and Air-Conditioning Engineers (ASHRAE).

BACnet is an American national standard, a European standard, a national standard in more than 30 countries and an ISO global standard. The protocol is supported and maintained by ASHRAE Standing Standard Project committee 135.

For further information, please visit www.bacnet.org

COMMUNICATION

Connection	BACnet		DALI
	MSTP	IP	
Data rate	EIA485 (3 wire isolated) 9.6, 19.2, 38.4, 57.6, 76.8, 115.2kbps	10BASE-T 100BASE-TX 10 Mbps 100 Mbps	DALI 1.2 kbps
Data Types & Functions supported	Object types 0-AO (Analog Output) 1-AI (Analog Input) 2-AV (Analog Value) 3-BO (Binary Output) 4-BI (Binary Input) 5-BV (Binary Value) 13-MI (Multistate Input) 14-MO (Multistate Output) 15-MV (Multistate Value)	Functions Trend Logs Calendars Schedules	Part 201: Fluorescent lights (DALI type 0) Part 202: Emergency lights (DALI type 1) Part 207: LED modules (DALI type 6) Part 103: Control devices Part 303: Occupancy sensors Part 304: Light sensors

ELECTRICAL & MECHANICAL FEATURES

Enclosure	Plastic, type PC (UL 94 V-0) Net dimensions (dxwxh): 90x88x56 mm Recommended space for installation (dxwxh): 130x100x100mm Color: Light Grey, RAL 7035
Mounting	Wall. DIN rail EN60715 TH35.
Terminal Wiring (for power supply and low-voltage signals)	Per terminal: solid wires or stranded wires (twisted or with ferrule) 1 core: 0.5mm ² ... 2.5mm ² 2 cores: 0.5mm ² ... 1.5mm ² 3 cores: not permitted If cables are more than 3.05 meters long, Class 2 cable is required.
Power	1 x Plug-in screw terminal block (3 poles) Positive, Negative, Earth 24VDC +/-10%
Ethernet	1 x Ethernet 10/100 Mbps RJ45 2 x Ethernet LED: port link and activity
Port A	1 x DALI port (Plug-in screw terminal block orange 2 poles) 1500VDC isolation from other ports DALI guaranteed power: 235mA Voltage rating: 16VDC 1 x Plug-in screw terminal block green (2 poles) Reserved for future use
Switch A (SWA)	1 x DIP-Switch for serial EIA485 configuration: Reserved for future use
PORT B	NDAL-0640200-BAC 1 x Serial EIA232 (SUB-D9 male connector) Reserved for future use 1 x Serial EIA485 Plug-in screw terminal block (3 poles) A, B, SG (Reference ground or shield) 1500VDC isolation from other ports (except PORT B: EIA232) NDAL-1280200-BAC 1 x Serial EIA232 (SUB-D9 male connector) Reserved for future use 1 x DALI port (Plug-in screw terminal block green 2 poles) 1500VDC isolation from other ports DALI guaranteed power: 235mA Voltage rating: 16VDC
Switch B (SWB)	1 x DIP-Switch for serial EIA485 configuration: Position 1: ON: 120 Ω termination active Off: 120 Ω termination inactive Position 2-3: ON: Polarization active Off: Polarization inactive

Battery	Size: Coin 20mm x 3.2mm Capacity: 3V / 225mAh Type: Manganese Dioxide Lithium
Console Port	Mini Type-B USB 2.0 compliant 1500VDC isolation
USB port	Type-A USB 2.0 compliant Only for USB flash storage device (USB pen drive) Power consumption limited to 150mA (HDD connection not allowed)
Push Button	Button A: Check the user manual Button B: Check the user manual
Operation Temperature	0°C to +50°C
Operational Humidity	5 to 95%, no condensation
Protection	IP20 (IEC60529)
LED Indicators	10 x Onboard LED indicators 2 x Run (Power)/Error 2 x Ethernet Link/Speed 2 x Port A TX/RX 2 x Port B TX/RX 1 x Button A indicator 1 x Button B indicator

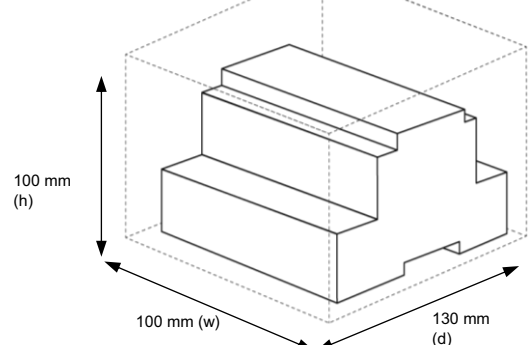

DALI to BACnet IP Server Gateway

NDAL-0640500-BAC



DESCRIPTION

Integrated any DALI/DALI-2 driver and DALI-2 light sensor, or occupancy sensor with a BACnet CMS or any BACnet IP controller. The aim of this integration is to make DALI devices and its data and resources accessible from a BACnet based control system or device, as it was a part of the own BACnet system and vice-versa.

This bidirectional gateway provides a straightforward and fast integration thanks to its unique onboard features.

The BTL mark ensures 100% compatibility and, at the same time, guarantees a seamless integration with any BACnet device.

The configuration is carried out using the Nindoma MAPS software. This one allows you to define your own settings for the device. Also, it will be able to download all the available project templates or to import any created/exported project template on your computer.

FEATURES

- UL Certified ; BTL Certified ; DALI-2 Certified
- Support for BACnet IP Client
- BACnet Advanced features available (Trend logs, Calendars, etc.)
- Support for DALI & DALI-2 drivers and DALI-2 Input devices including : Push buttons, Absolute inputs, Occupancy and Light sensors
- Integrated DALI power supply
- 1 DALI channel
- Up to 64 drivers/ballasts + 16 DALI-2 sensors per channel (Guaranteed DALI supply : 235mA)
- Easy integration & DALI commissioning with Nindoma MAPS

INTEGRATION EXAMPLE

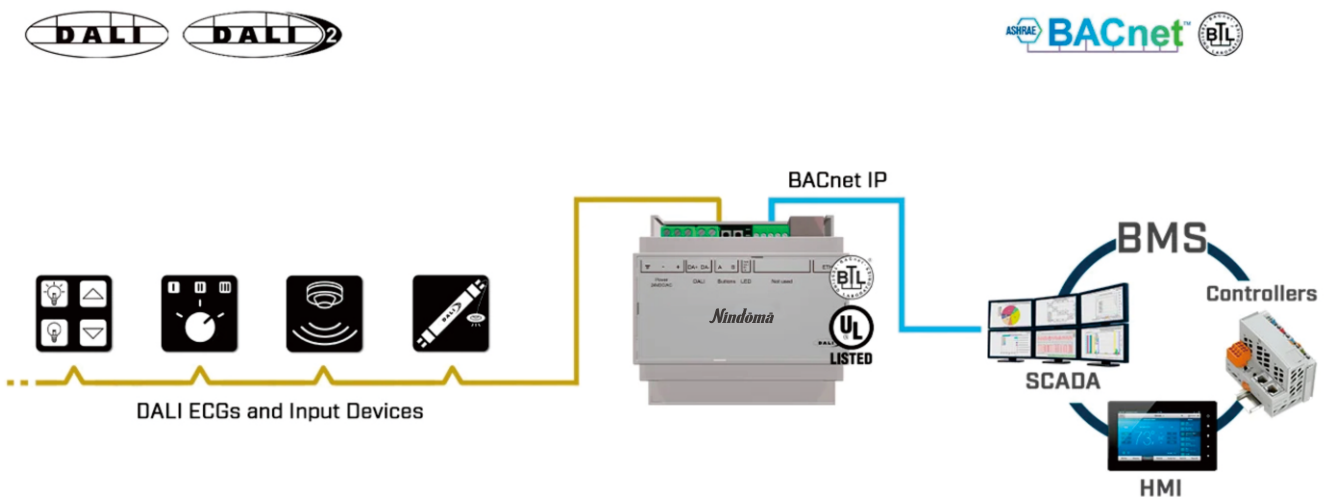

CONNECTIONS

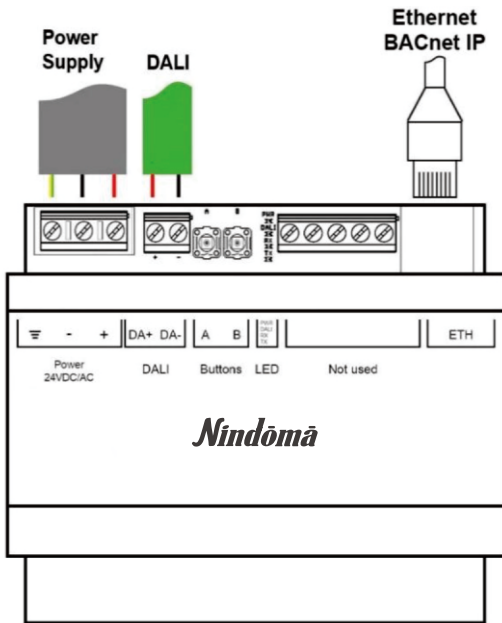

Power Supply

Must use NEC Class 2 or Limited Power Source (LPS) and SELV rated power supply. Respect polarity applied of terminals (+) and (-). Be sure the voltage applied is within the range admitted (check table below). The power supply can be connected to earth but only through the negative terminal, never through the positive terminal.

Ethernet / BACnet IP(UDP) / Console (UDP & TCP)

Connect the cable coming from the IP network to the connector ETH of the gateway. Use an Ethernet CAT5 cable. If communicating through the LAN of the building, contact the network administrator and make sure traffic on the port used is allowed through all the LAN path (check the gateway user manual for more information). With factory settings, after powering up the gateway, DHCP will be enabled for 30 seconds. After that time, if no IP is provided by a DHCP server, the default IP 192.168.100.246 will be set.

DALI

Connect the DALI bus to connectors DA+, DA- of gateway's DALI port. The Nindoma gateway provides 16VDC DALI voltage to the bus. Please, respect polarity when other DALI power supplies are connected in the same DALI bus.

ELECTRICAL & MECHANICAL FEATURES

Enclosure	Plastic, type PC (UL 94 V-0) Net dimensions (d×w×h): 88x106x56 mm Recommended space for installation (d×w×h): 130x115x100mm Color: Light Grey. RAL 7035
Mounting	Wall. DIN rail EN60715 TH35.
Terminal Wiring (for power supply and low-voltage signals)	Per terminal: solid wires or stranded wires (twisted or with ferrule) 1 core: 0.5mm ² ... 2.5mm ² 2 cores: 0.5mm ² ... 1.5mm ² 3 cores: not permitted
Power	1 x Plug-in screw terminal block (3 poles) Positive, Negative, Earth 24VDC/AC +/-10% 6W(250mA)
Ethernet	1 x Ethernet 10/100 Mbps RJ45 2 x Ethernet LED: port link and activity
DALI	1 x DALI port (Plug-in screw terminal block 2 poles) 1500VDC isolation from other communication ports DALI guaranteed power: 230mA DALI maximum power:250mA Voltage rating: 16VDC

Push Button	Button A: Check the user manual Button B: Check the user manual
Operation Temperature	0°C to +50°C
Operational Humidity	5 to 95%, no condensation
Protection	IP20 (IEC60529)
LED Indicators	6 x On board LED indicators 1 x Power LED (Green) 1 x DALI (Yellow) 1 x RX (Green) 1 x TX (Yellow) 1 x Button A indicator 1 x Button B indicator

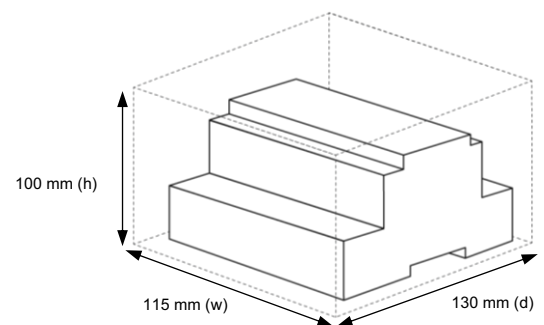

DALI to Modbus TCP Server Gateway

NDAL-0640500-MBS



DESCRIPTION

Integrate any DALI/DALI-2 driver and DALI-2 light sensor, or occupancy sensor with a Modbus BMS or any Modbus TCP controller. The aim of this integration is to make DALI devices and its data and resources accessible from a Modbus based control system or device, as if it was a part of the own Modbus system and vice-versa.

This bidirectional gateway provides a straightforward and fast integration thanks to its unique onboard features.

Thanks to its support for both Modbus RTU and TCP, with the possibility to work together at the same time, a seamless integration with any Modbus BMS or controller it is guaranteed.

The configuration is carried out using the Nindoma MAPS software. This one allows you to define your own settings for the device. Also, it will be able to download all the available project templates or to import any created/exported project template on your computer.

FEATURES

- UL Certified ; DALI-2 Certified
- Support for up to 5 simultaneous Modbus TCP Clients
- Support for DALI & DALI-2 drivers & DALI-2 Input devices including : Push buttons, Absolute inputs, Occupancy and Light sensors Integrated DALI power supply
- 1 DALI channel
- Up to 64 drivers/ballasts + 16 DALI-2 sensors per channel (Guaranteed DALI supply : 235mA)
- Easy integration & DALI commissioning with Nindoma MAPS

INTEGRATION EXAMPLE

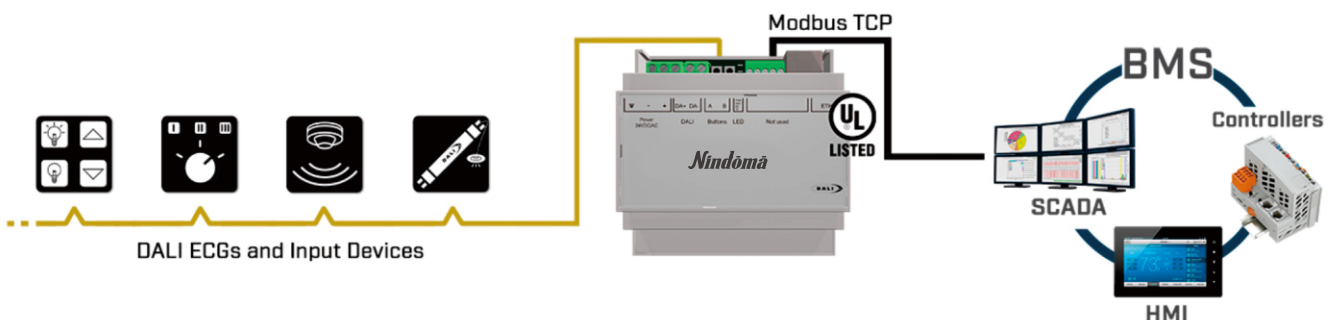

CONNECTIONS

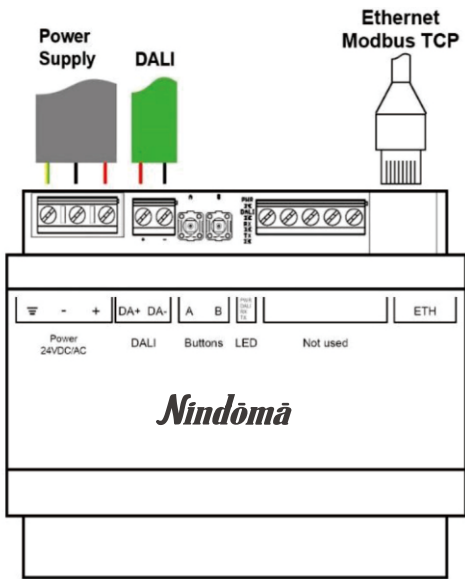

Power Supply

Must use NEC Class 2 or Limited Power Source (LPS) and SELV rated power supply. Respect polarity applied of terminals (+) and (-). Be sure the voltage applied is within the range admitted (check table below). The power supply can be connected to earth but only through the negative terminal, never through the positive terminal.

Ethernet / Modbus TCP / Console (UDP & TCP)

Connect the cable coming from the IP network to the connector ETH of the gateway. Use an Ethernet CAT5 cable. If communicating through the LAN of the building, contact the network administrator and make sure traffic on the port used is allowed through all the LAN path (check the gateway user manual for more information). With factory settings, after powering up the gateway, DHCP will be enabled for 30 seconds. After that time, if no IP is provided by a DHCP server, the default IP 192.168.100.246 will be set.

DALI

Connect the DALI bus to connectors DA+, DA- of gateway's DALI port. The Nindoma gateway provides 16VDC DALI voltage to the bus. Please, respect polarity when other DALI power supplies are connected in the same DALI bus.

ELECTRICAL & MECHANICAL FEATURES

Enclosure	Plastic, type PC (UL 94 V-0) Net dimensions (d×w×h): 88x106x56 mm Recommended space for installation (d×w×h): 130x115x100mm Color: Light Grey. RAL 7035
Mounting	Wall. DIN rail EN60715 TH35.
Terminal Wiring (for power supply and low-voltage signals)	Per terminal: solid wires or stranded wires (twisted or with ferrule) 1 core: 0.5mm ² ... 2.5mm ² 2 cores: 0.5mm ² ... 1.5mm ² 3 cores: not permitted
Power	1 x Plug-in screw terminal block (3 poles) Positive, Negative, Earth 24VDC/AC +/-10% 6W(250mA)
Ethernet	1 x Ethernet 10/100 Mbps RJ45 2 x Ethernet LED: port link and activity
DALI	1 x DALI port (Plug-in screw terminal block 2 poles) 1500VDC isolation from other communication ports DALI guaranteed power: 230mA DALI Maximum Power: 250mA Voltage rating: 16VDC

Push Button	Button A: Check the user manual Button B: Check the user manual
Operation Temperature	0°C to +50°C
Operational Humidity	5 to 95%, no condensation
Protection	IP20 (IEC60529)
LED Indicators	6 x On board LED indicators 1 x Power LED (Green) 1 x DALI (Yellow) 1 x RX (Green) 1 x TX (Yellow) 1 x Button A indicator 1 x Button B indicator

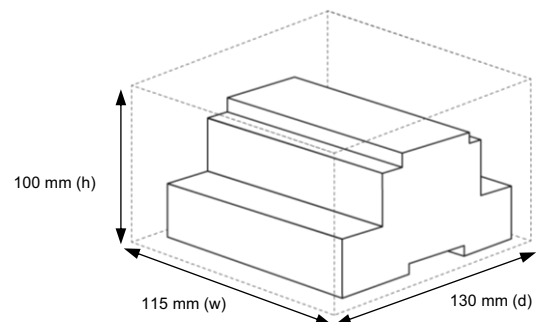

Relay Controller

NDLR05-1



- ▶ Compliance with Safty standar IEC 60669-2-1 : 2002
- ▶ ABS Plastic case with terminal protection waterproof cover
- ▶ Minimized volume, easy intallation and placement
- ▶ EC62386 DALI agreement with the standard; with any the DALI agreement with equipment to put up a bus control
- ▶ Has one channel 5A/250VAC relay switching output,
- ▶ DALI communication interface with isolation protection function
- ▶ Applicable to family office, hotel, and engineering
- ▶ Supply : AC90~240V 50Hz/60Hz ; Power consumption : ≤10W
- ▶ Input Signal DALIbus ; Relay current : 5A/250VAC
- ▶ Working Temp : -20°C - 75°C ; Relativ Humidity : 10-90%
- ▶ Weight : 110gram ; Size : 132*44*23.5mm

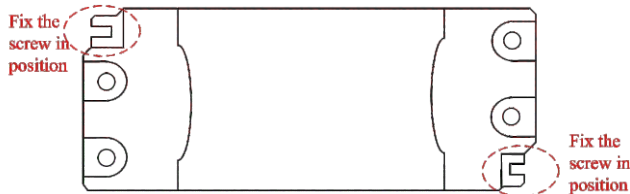

Installed on both ends of the position using the 3mm screw (nedd to bring your own)

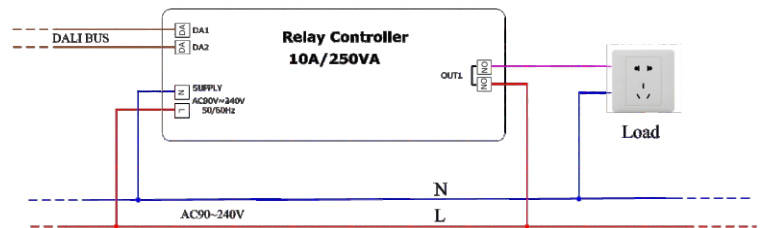

Wiring Diagram (Wire : BV1.5 square copper wire is recommended, with good contact and low heat)

- ▶ Note : Unable to connect the inductive load
- ▶ Application

All of the parameter setting and operating is fulfilled by the DALI master giving orders to DALI protocol, and this product accept any standard protocol. For the detail operation explanation, please refer to related files of master device.

- ▶ Transportation and storage

In transportation, make sure the product is in packing, and avoid violent vibration. The Temperature should be between -20°C - 70°C while the Relative humidity should be below 90%. Make sure no corrosive gas in air.

Relay Controller

NDLR10-1



(10A/250VA)

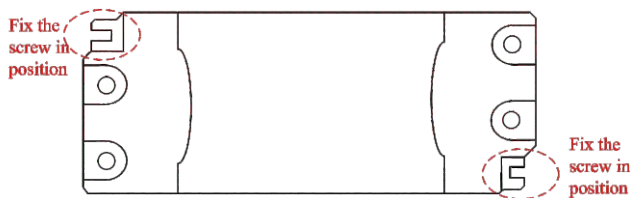

Installed on both ends of the position using the 3mm screw (need to bring your own)

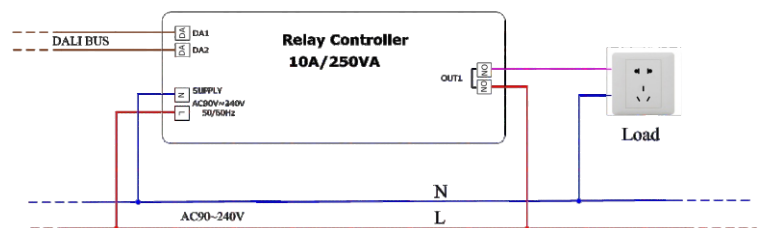

Wiring Diagram (Wire : BV1.5 square copper wire is recommended, with good contact and low heat)

- ▶ Compliance with Safty standar IEC 60669-2-1 : 2002
- ▶ ABS Plastic case with terminal protection waterproof cover
- ▶ Minimized volume, easy intallation and placement
- ▶ Conform to IEC62386 protocol standard
- ▶ Using new type magnetic latching relay, energy saving, low heat
- ▶ With one independent control 10A/250VAC, dry contact output, Occupy a dali address
- ▶ The signal control interface has the function of photoelectric isolation and high voltage protection
- ▶ Suitbale for home, office, hotel, engineering, etc
- ▶ Supply : AC90~240V 50Hz/60Hz ; Power consumption : $\leq 3W$
- ▶ Input Signal : Dalibus <2mA (accord with IEC62386 protocol standard; Can be connected with any device that conforms to the protocol with a bus control, Occupy a bus address
- ▶ Output : 10A/250VAC*1CH(dry contact output of magnetic latching relay)
- ▶ Dimming Level : On/Off ; Working Temp : -20°C - 50°C
- ▶ Relativ Humidity : 10-90% ; Weight : 120gram ; Size : 140*45*27mm

▶ Note :

Requires to select the total power of access electronic swith, pure resistive load (such as Incandescent lamp) limit within 2000W @AC220V, no-pure resistance load (such as LED dimming power supply, swithing power supply, electrical appliances, etc.) depending on the impact current situation need to reduce at least 50%-80% power use; It is recommended to control the AC voltage.

▶ Application

All of the parameter setting and operating is fulfilled by the master device giving oredes from the IEC62386 protocol, and this product can accept any standard protocol of device type 7 (Dt7). For the detail operation explanation, please refer to related files of master device.

▶ Transportation and storage

In transportation, make sure the product is in packing, and avoid violent vibration. The Temperature should be between -20°C - 55°C while the Relative humidity should be below 90%. Make sure no corrosive gas in air.

Relay Controller NDLR10-2



- ▶ Compliance with Safty standar IEC 60669-2-1 : 2002
- ▶ ABS Plastic case with terminal protection waterproof cover
- ▶ Minimized volume, easy intallation and placement
- ▶ EC62386 DALI agreement with the standard; with any the DALI agreement with equipment to put up a bus control
- ▶ Has two channel 10A/250VAC relay switching output,
- ▶ DALI communication interface with isolation protection function
- ▶ Applicable to family office, hotel, and engineering
- ▶ Supply : AC90~240V 50Hz/60Hz ; Power consumption : $\leq 3W$
- ▶ Input Signal DALIbus ; Relay current : 10A/250VAC *2
- ▶ Working Temp : -20°C - 75°C ; Relativ Humidity : 10-90%
- ▶ Weight : 130gram ; Size : 140*45*27mm

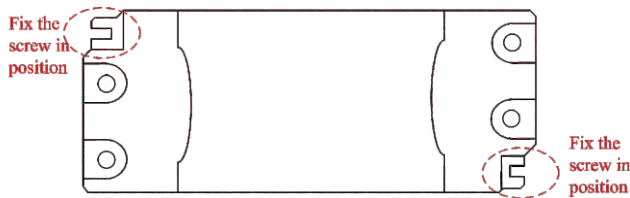

Installed on both ends of the position using the 3mm screw (nedd to bring your own)

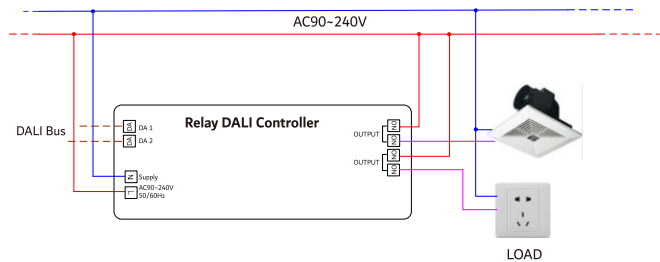

Wiring Diagram (Wire : BV1.5 square copper wire is recommended, with good contact and low heat)

▶ Note : Unable to connect the inductive load

▶ Application

All of the parameter setting and operating is fulfilled by the DALI master giving orders to DALI protocol, and this product accept any standard protocol. For the detail operation explanation, please refer to related files of master device.

▶ Transportation and storage

In transportation, make sure the product is in packing, and avoid violent vibration. The Temperature should be between -20°C - 70°C while the Relative humidity should be below 90%. Make sure no corrosive gas in air.

DALI Knob Panel Manual

N6-DAI1

Mounting & Dismounting Instructions

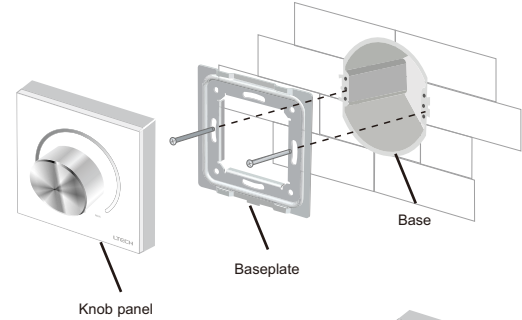

Typical base are as follow:

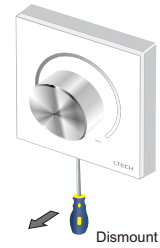
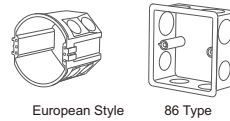

Product Features

- ▶ Adopt latest DALI standard protocol IEC62386
- ▶ Support switch and dimming function
- ▶ Powered by DALI bus
- ▶ Easy to set DALI address
- ▶ Support group, unicast, broadcast mode

Technical Specs

- ▶ Power supply DALI bus; Output Signal DALI
- ▶ Dimming Style Rotary control
- ▶ Static Current 6mA@16V
- ▶ Standby Current 4mA@16V
- ▶ Working Temp : -10°C~55°C
- ▶ Dimensions (LxWxH) : 86x86x50mm
- ▶ Package Size (LxWxH) : 106x106x60mm
- ▶ Weight (G.W.) : 235gram

Wiring Diagram

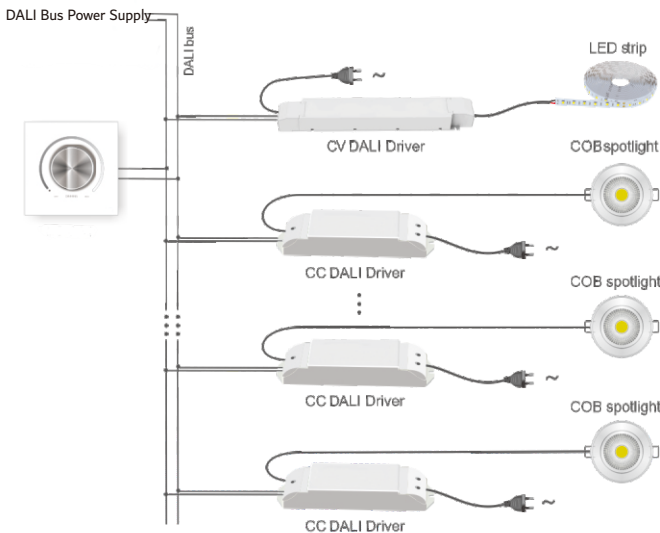

Product Size

Unit: mm

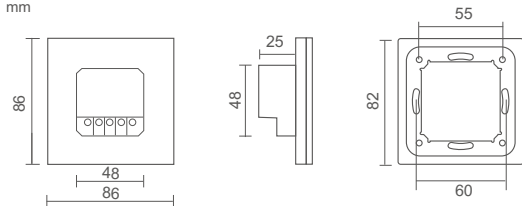

Key Functions



- * Turn the knob clockwise, the brightness increases.
- * Turn the knob counterclockwise, the brightness decreases. Turn the knob counterclockwise to the end, the dimmer will be turned off (A click can be heard).

Terminals

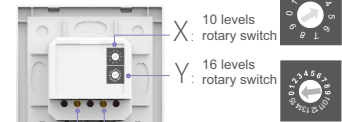

Power and signal combination sockets

DALI Address Settings

X = (0-6): unicast mode; X = 7: group mode; X = 8 or 9: broadcast mode.
Via rotary switch, you can set 64 unicast addresses (0-63), 16 group addresses (0-15) and broadcast address.

Unicast mode (address: 0-63)

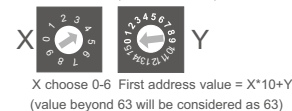

E.g.: Set initial address to 40 in unicast mode.

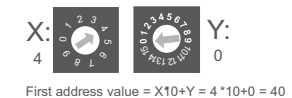

Group mode (address:0-15)



E.g.: Set initial address to 5 in group mode.



Broadcast mode



DALI Touch Panel Manual

N-EDA1; N-EDA2; N-EDA3; N-EDA4

Mounting & Dismounting Instructions & Size

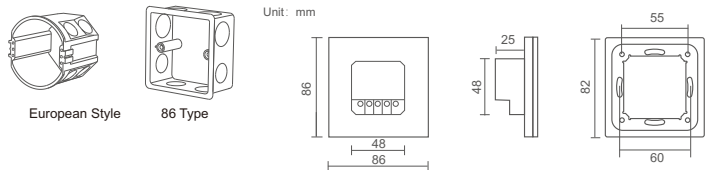
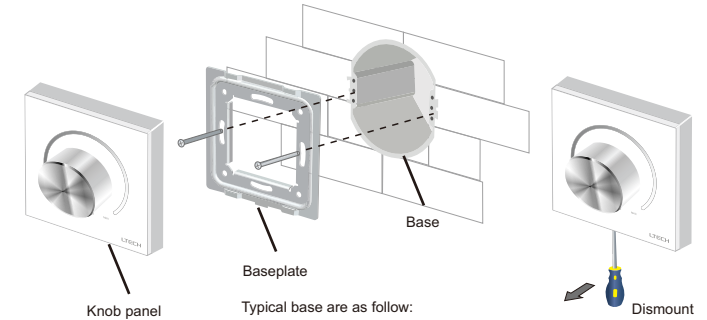
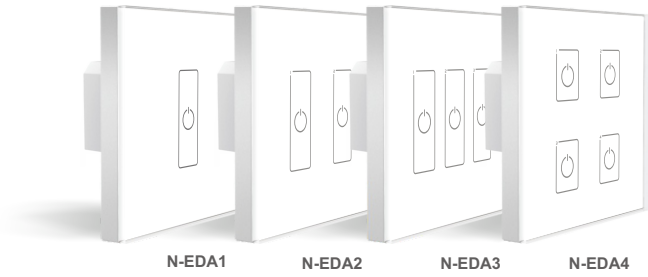

Product Features

- ▶ Adopt latest DALI standard protocol IEC62386
- ▶ Support switch and dimming function
- ▶ Powered by DALI bus
- ▶ Easy to set DALI address
- ▶ Support group, unicast, broadcast mode

Technical Specs

- ▶ Power supply DALI bus; Output Signal DALI
- ▶ Static Current 6mA@16V
- ▶ Standby Current 4mA@16V
- ▶ Working Temp : -30°C~55°C
- ▶ Dimensions (LxWxH) : 86x86x37mm
- ▶ Package Size (LxWxH) : 113x112x50mm
- ▶ Weight (G.W.) : 200gram

Panel Key Description

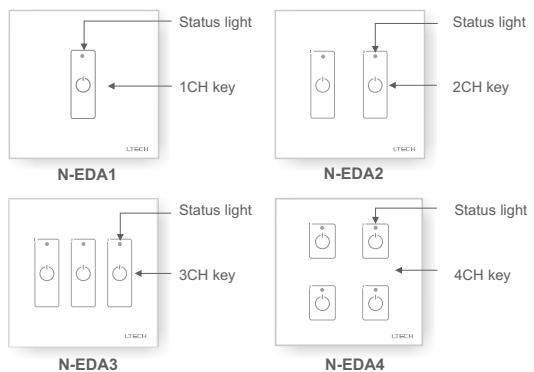

* Short press: switch; long press: dimming (suitable for unicast, broadcast and group mode).

Terminals

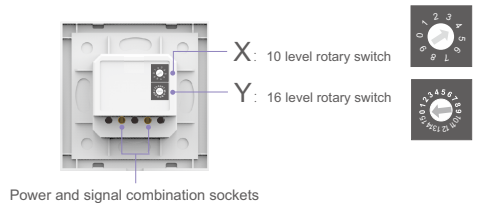

DALI Address Settings

X= (0-6): unicast mode; X= 7: group mode; X= 8: scene mode; X= 9: broadcast mode.
Via spin switch, you can set 64 unicast addresses(0-63), 16 group addresses(0-15), 16 scene addresses(0-15) and broadcast address.

Unicast mode (address:0-63)

E.g.: Set initial address to 40 in unicast mode.

X: 4 Y: 0
First address value = X*10+Y = 4*10+0 = 40

Group mode (address:0-15)

E.g.: Set initial address to 5 in group mode.

X: 7 Y: 5
First address value = Y

Scene mode (address:0-15)

E.g.: Set initial address to 14 in scene mode.

X: 8 Y: 14
First address value = Y

Broadcast mode

X: 9
X choose 9

Wiring Diagram

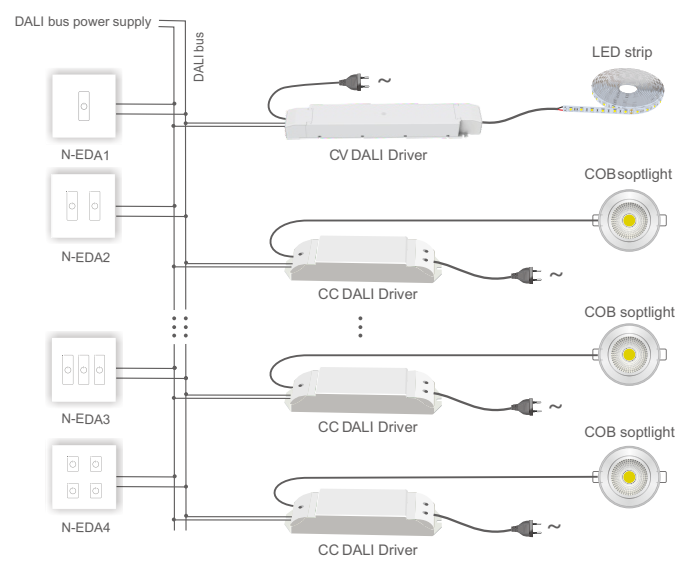

Nindōmā

Thank You



www.nindoma.com

@CtgNDM0922 | DALI Control System